

| Item | Qty. | Description |
|------|------|-----------------------------------|
| 1 | 1 | 40”h S40 Vertical Extrusion |
| 2 | 1 | 40”h S40 Vertical Extrusion |
| 3 | 1 | 40”h S40 Vertical Extrusion |
| 4 | 1 | 40”h S40 Vertical Extrusion |
| 5 | 1 | 13.480”w S40 Horizontal Extrusion |
| 6 | 1 | 13.480”w S40 Horizontal Extrusion |
| 7 | 1 | 13.480”w S40 Horizontal Extrusion |
| 8 | 1 | 13.480”w S40 Horizontal Extrusion |
| 9 | 1 | 19.480”w S40 Horizontal Extrusion |
| 10 | 1 | 19.480”w S40 Horizontal Extrusion |

Steps:

- 1) Assemble horizontals [5,6] between verticals [1,2], inserting **Infill**.
- 2) Attach horizontals [7,8] between verticals [3,4], inserting **Infill**.
- 3) Connect horizontals [9,10] between verticals [2,3].
- 4) Attach Shelf to verticals [1,2,3,4] using shelf pins.
See **Shelf Pin Attachment** detail
- 5) Connect Wings & Front Graphic to horizontals [9,10] as shown, using screw caps. See **Graphic Attachment** detail.
- 6) Place Counter Top onto assembly.

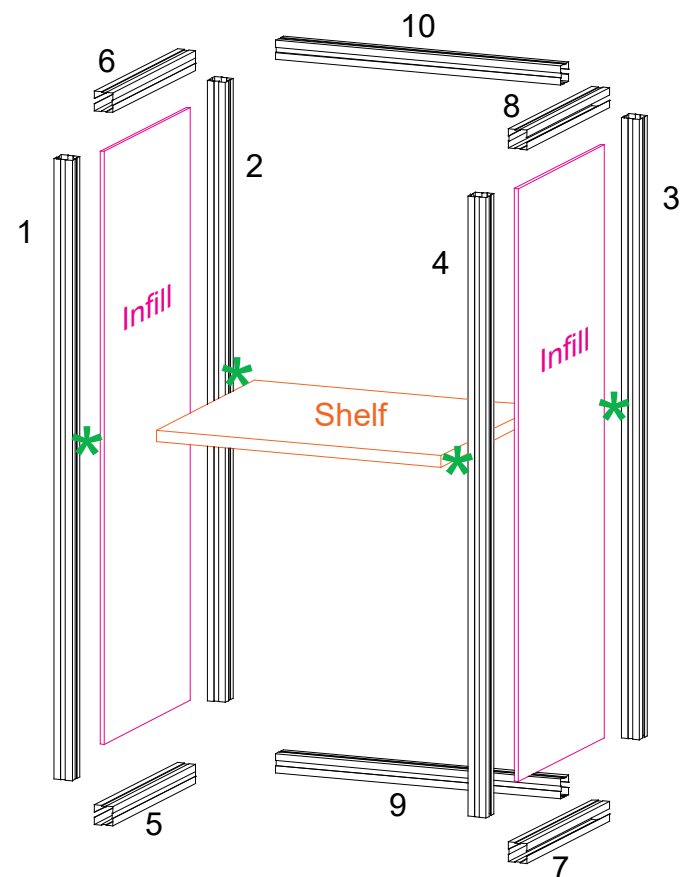
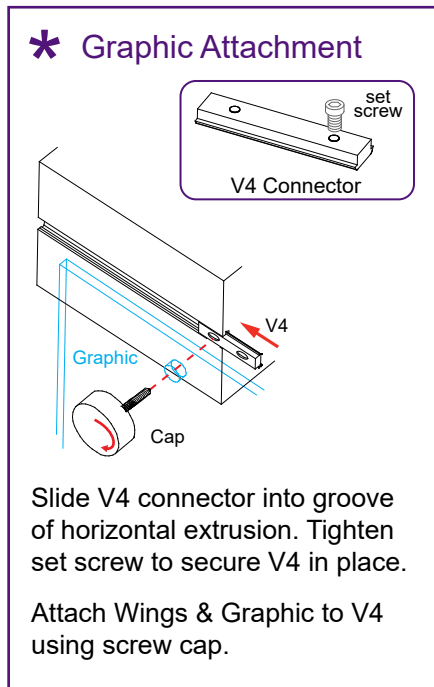
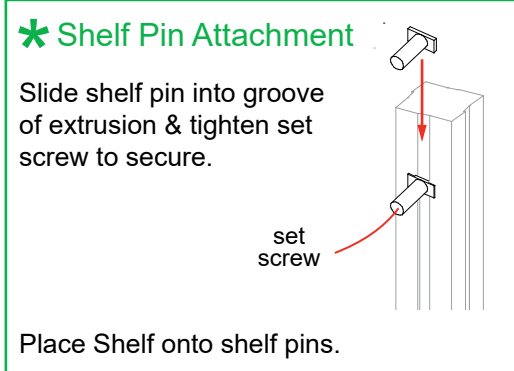

BACK VIEW

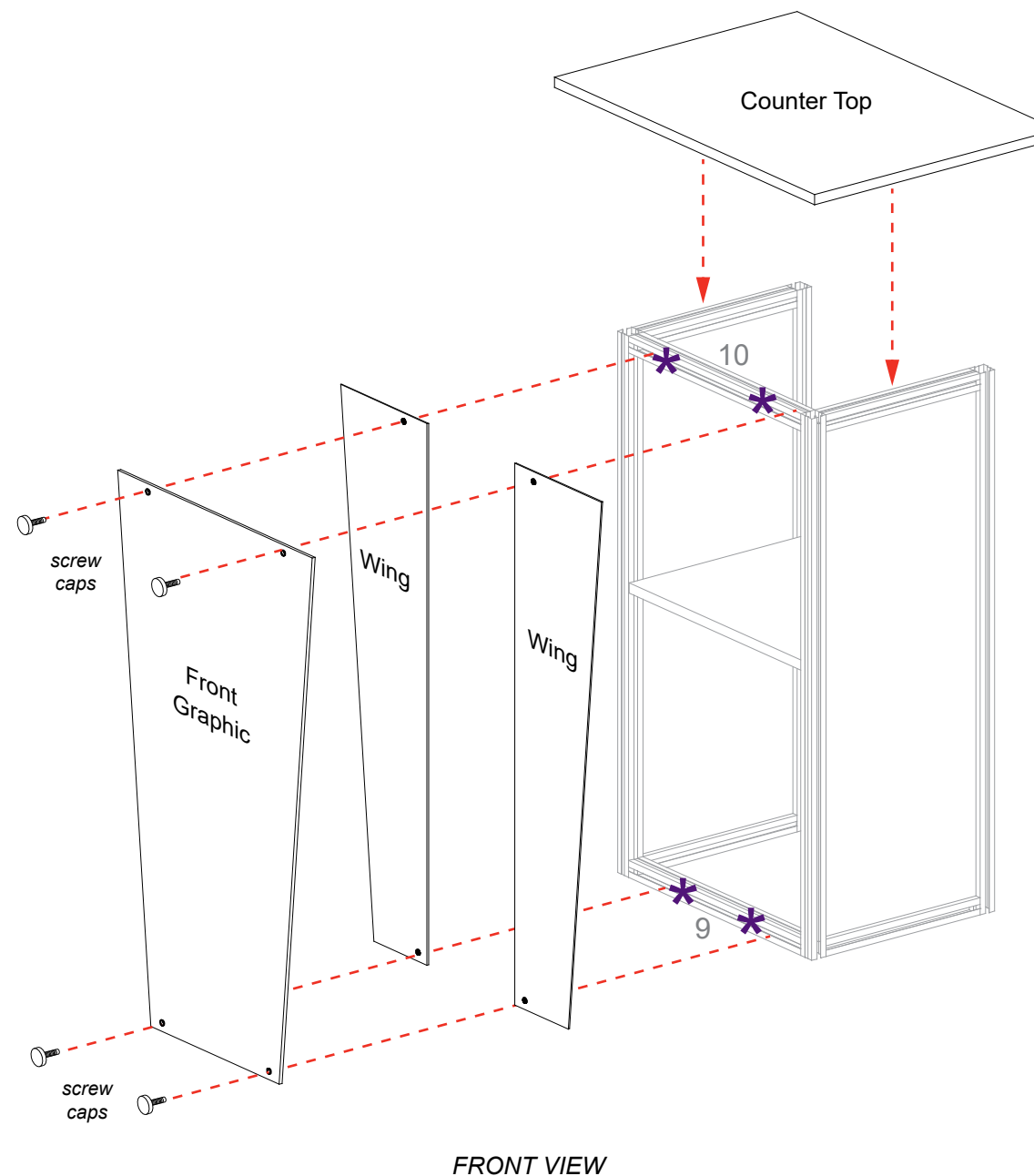

FRONT VIEW

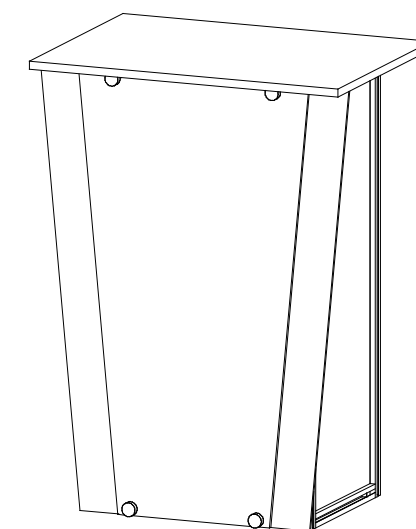

FRONT VIEW

When assembled

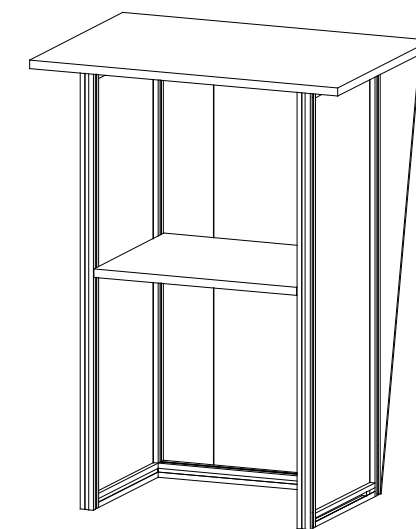

BACK VIEW

General Setup Instructions

- Read entire setup instruction manual prior to unpacking parts and pieces.
- The setup instructions are created specifically for this configuration.
- Setup instructions are laid out sequentially in steps, including exploded views with detailed explanation for assembly.

Cleaning & Packing

- For Cleaning Metal, Plex, & Laminate Parts: Use a **MILD NON-ABRASIVE** cleanser and soft cloth/paper towel to clean all surfaces.
- Keep exhibit components away from heat and prolonged sun exposure. **Heat and UV exposure will warp and fade components.**
- Retain all provided Packing Materials. All provided packing materials are for ease of repacking & component protection.

Disassembly

- For loss prevention, tighten all set screws and locks during disassembly.

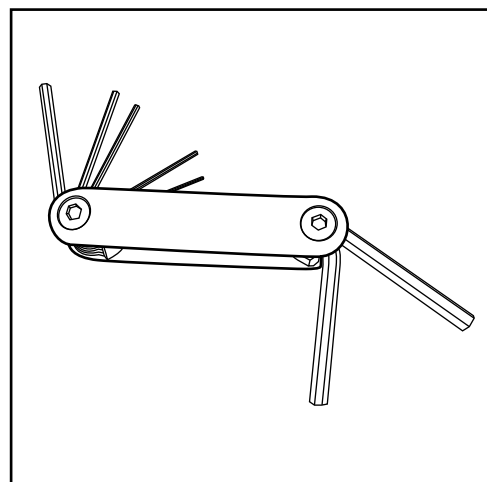

Hex Tool - Essential for Assembly

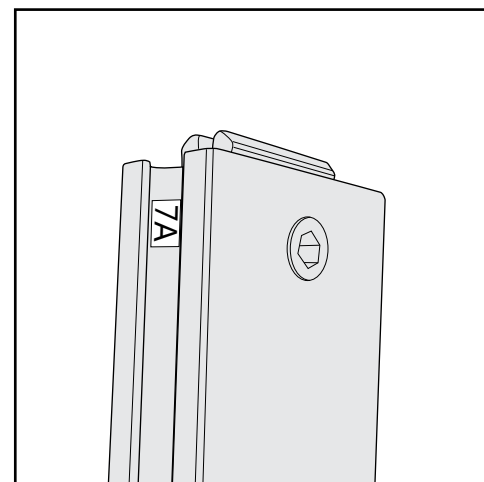

Part Identification - Numbering

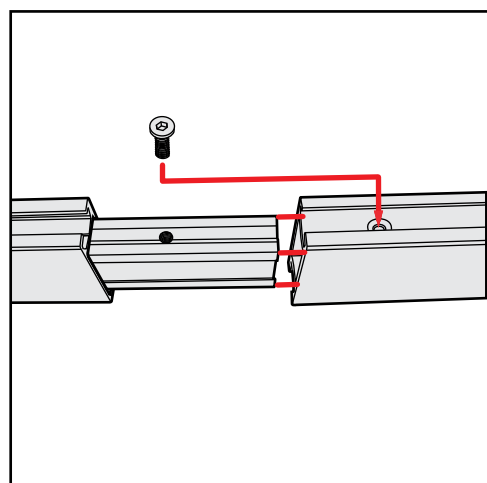

Spline Connection

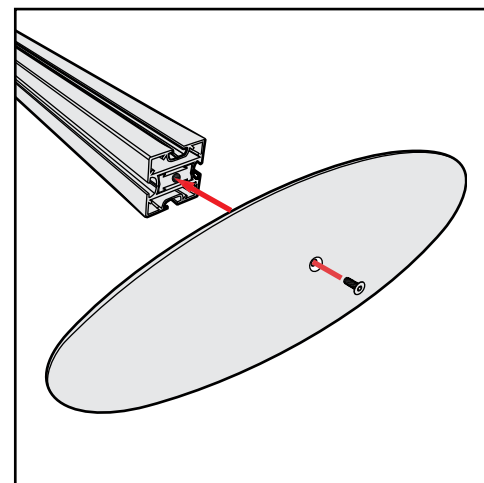

Base Plate & Extrusion Connection

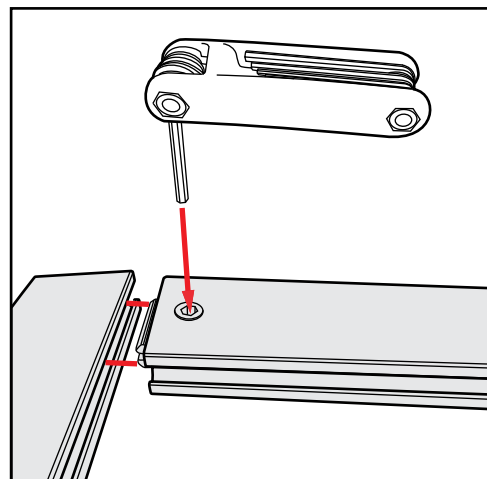

Extrusion & Lock Connection

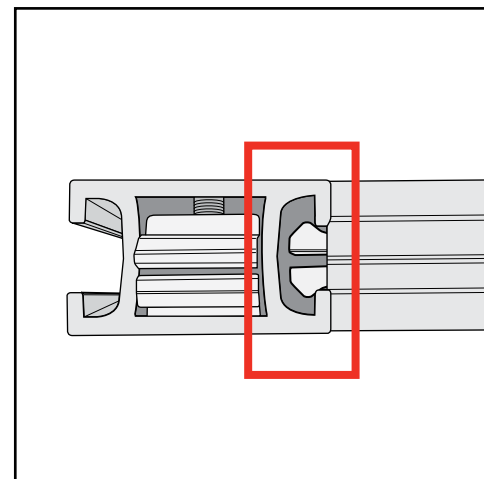

Engaged Lock



WARNING

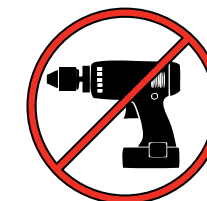

DO NOT USE POWER TOOLS



LADDERS OR LIFTS
MAY BE REQUIRED



ALL CONNECTIONS MUST
BE TIGHTLY SECURED

Top View of Each Level

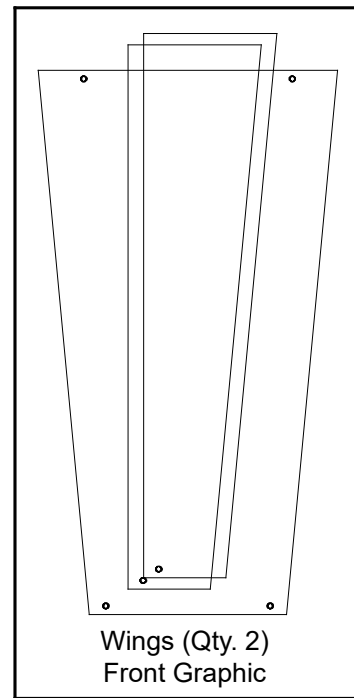

Level 1
(Bottom level)

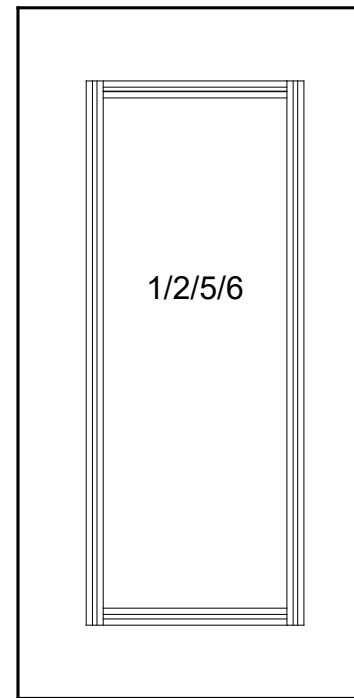

Level 2

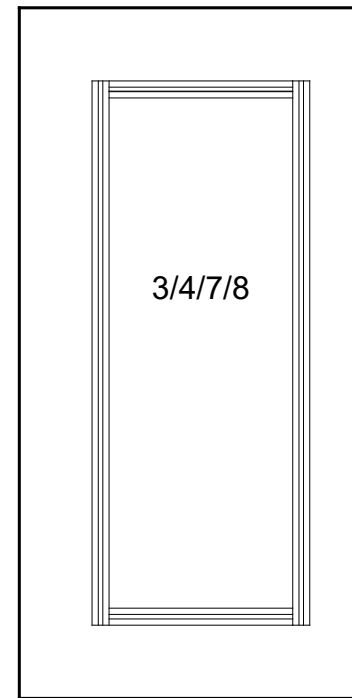

Level 3

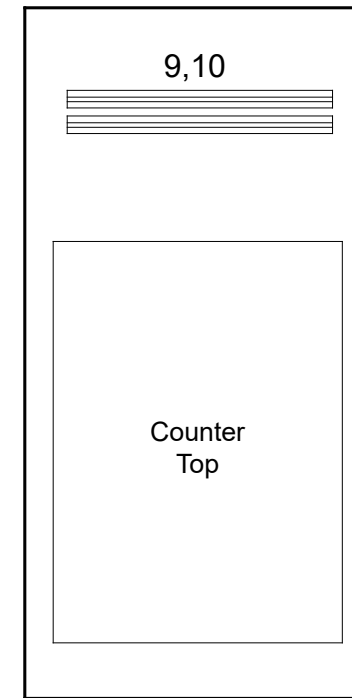

Level 4

