

Item	Qty.	Description
17	1	37.5" h Q914 Vertical Extrusion
18	1	37.5" h Q914 Vertical Extrusion
19	1	37.5" h Q914 Vertical Extrusion w/Door Hinges
20	1	37.5" h Q914 Vertical Extrusion w/Door Stop
21	1	32.5" h Q914 Vertical Extrusion
22	1	32.5" h Q914 Vertical Extrusion
23	5	13.5" w Z45 Horizontal Extrusion
24/24A	2/2	14.5" w Z45 Horizontal Extrusion
25	2	5.75" w Z45 Horizontal Extrusion
25A	2	7" w Z45 Horizontal Extrusion
--	1	PR63 Conduit

- Steps:**
- 1) Attach upper Vertical Extrusions [21,22] to lower Vertical Extrusions [19,20].
 - 2) Attach Horizontal Extrusions [23,24 and 24A] between Vertical Extrusions, placing **Infills** and attaching **Door** where indicated.
 - 3) Attach **Shelf Supports** to inside of assembled base using Velcro, then set Internal Shelf on top of supports.
 - 4) Attach [25,25A] to Verticals [17,18,19,20], then attach Shelves to Velcro on top of [25,25A].
 - 5) Place Counter Top on assembled base and secure with pins.
 - 6) Attach Monitor Mount to assembled workstation where indicated.
 - 7) Run cords through grommet in counter top & attach PR63 to vertical [22] as shown for wire management. See **PR63 Attachment** detail.

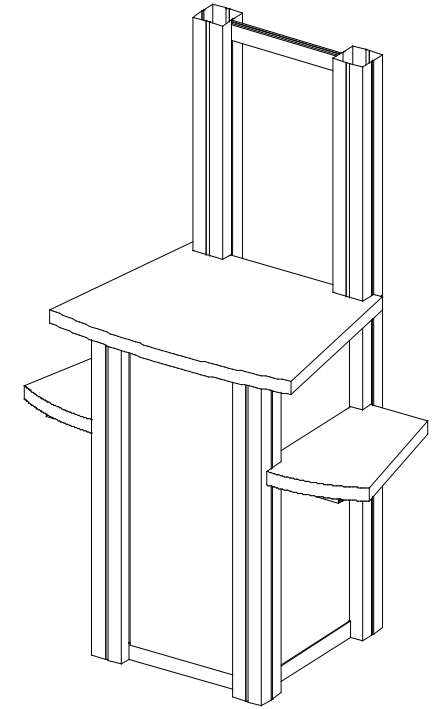

Completed Assembly

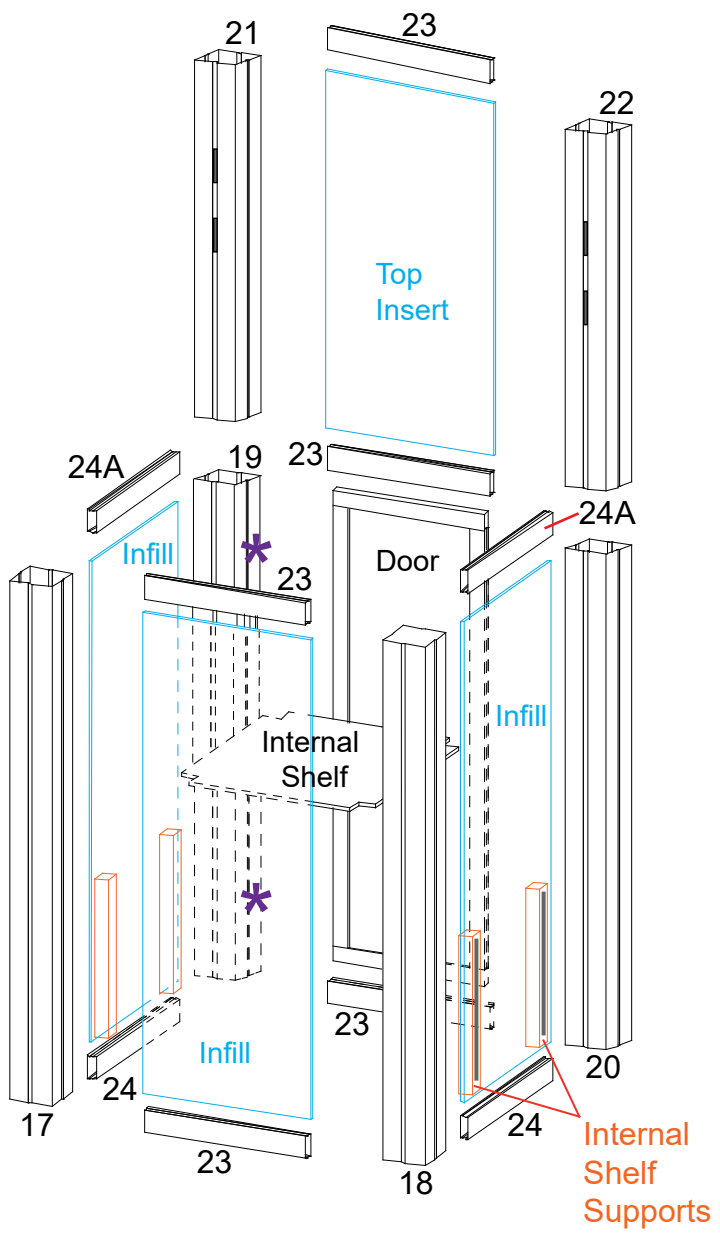

*** Monitor Mount Attachment**

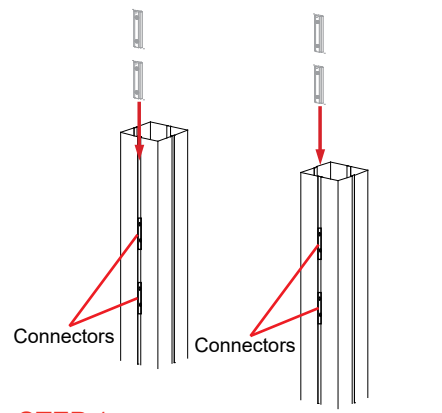

STEP 1
Slide Connectors into groove of extrusion. Tighten Set Screws to secure.

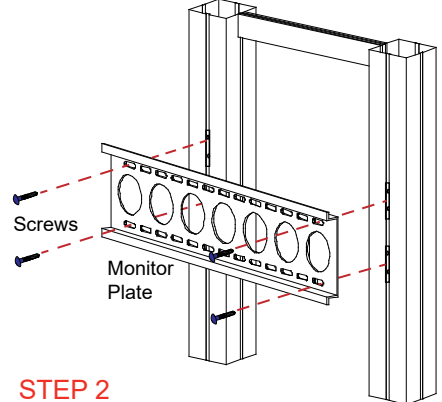

STEP 2
Attach Monitor Plate to Connectors, using supplied bolts.

*** Counter Top Attachment**

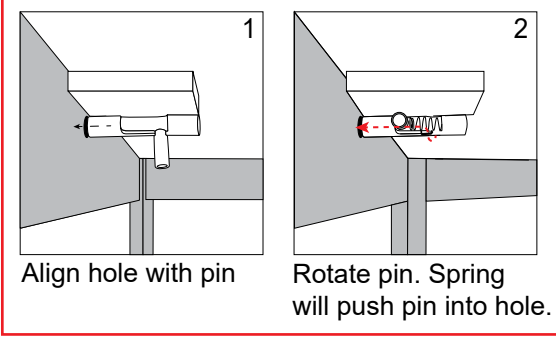

*** Door Attachment**

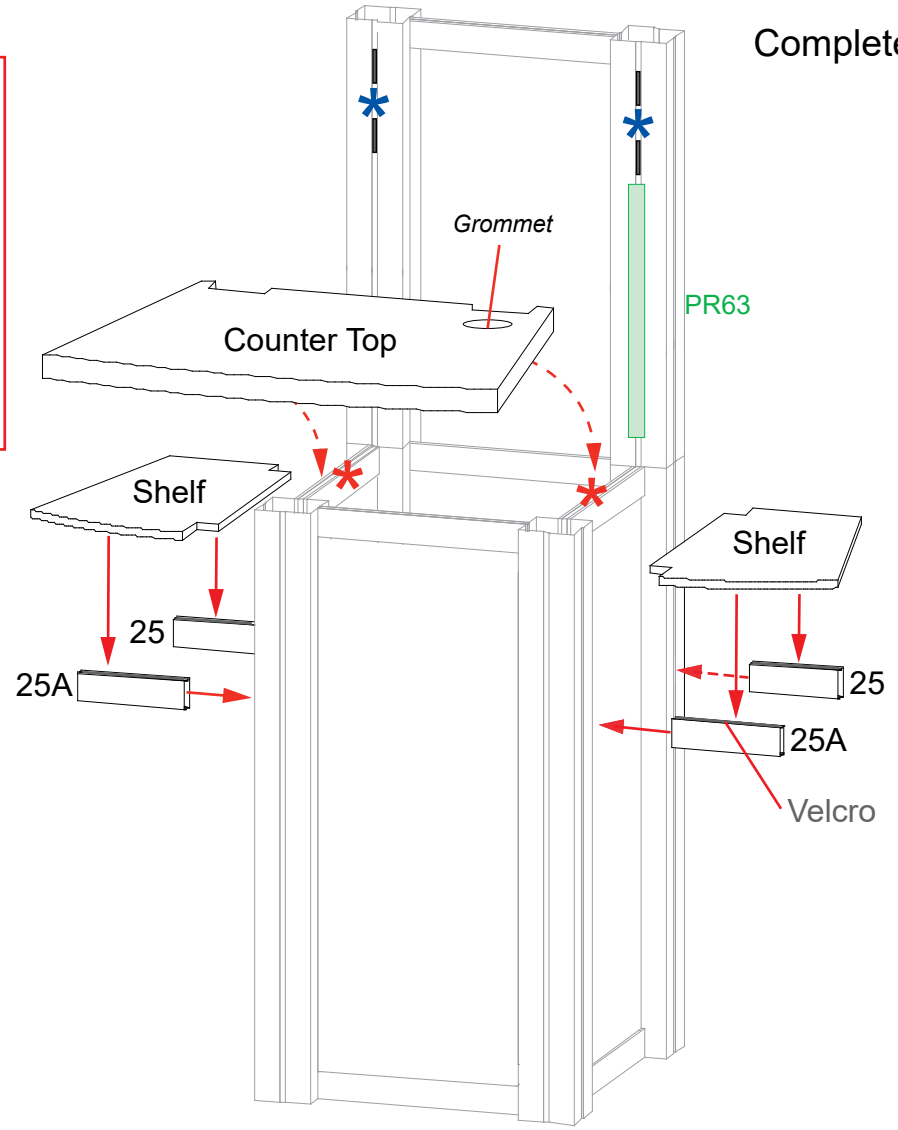
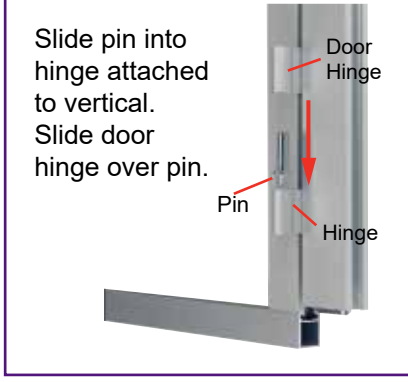

*** PR63 Attachment**

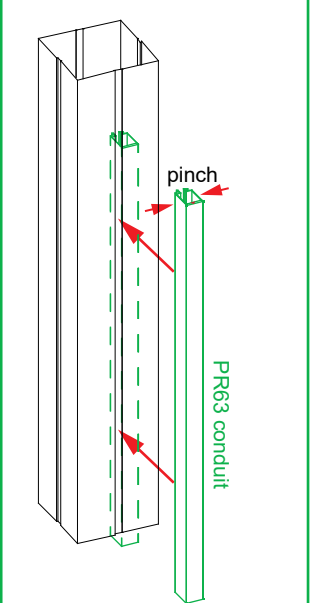

- 1) Run cords through PR63 plastic conduit.
- 2) Attach conduit where indicated by pinching the opening and inserting into the groove of extrusion.

SETUP INSTRUCTIONS

General Setup Instructions

- Read entire setup instruction manual prior to unpacking parts and pieces.
- The setup instructions are created specifically for this configuration.
- Setup instructions are laid out sequentially in steps, including exploded views with detailed explanation for assembly.

Cleaning & Packing

- For Cleaning Metal, Plex, & Laminate Parts: Use a **MILD NON-ABRASIVE** cleanser and soft cloth/paper towel to clean all surfaces.
- Keep exhibit components away from heat and prolonged sun exposure. **Heat and UV exposure will warp and fade components.**
- Retain all provided Packing Materials. All provided packing materials are for ease of repacking & component protection.

Disassembly

- For loss prevention, tighten all set screws and locks during disassembly.

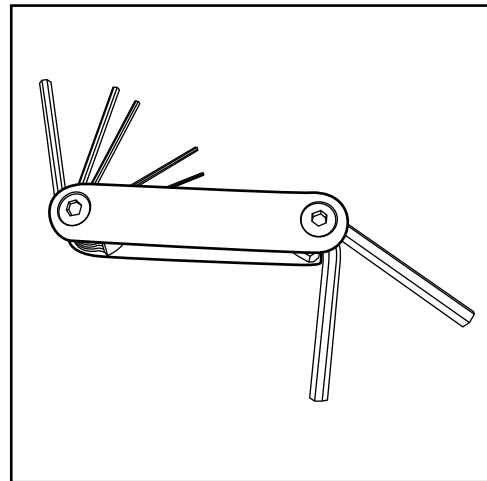

Hex Tool - Essential for Assembly

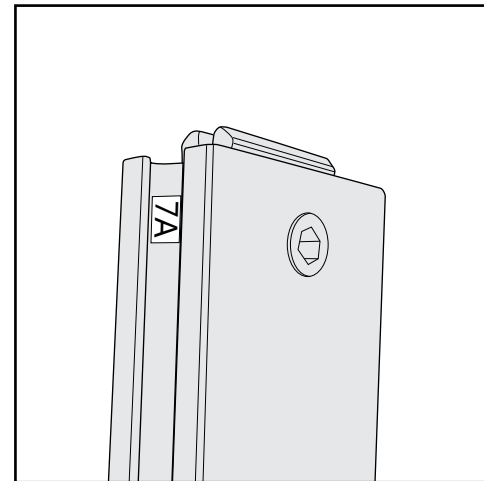

Part Identification - Numbering

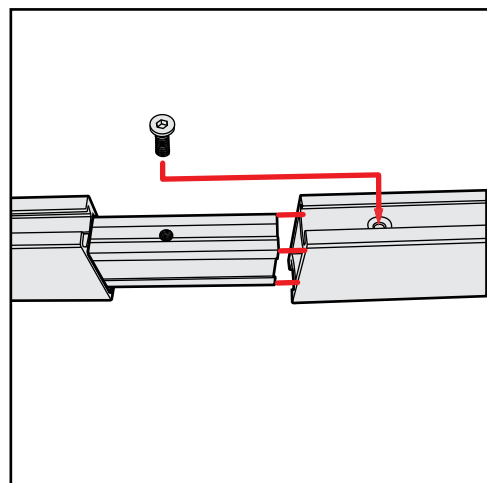

Spline Connection

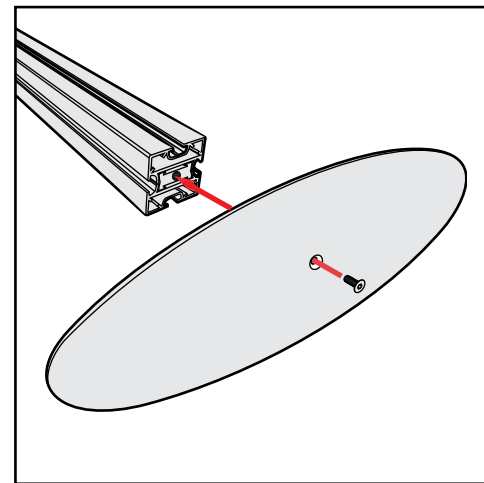

Base Plate & Extrusion Connection

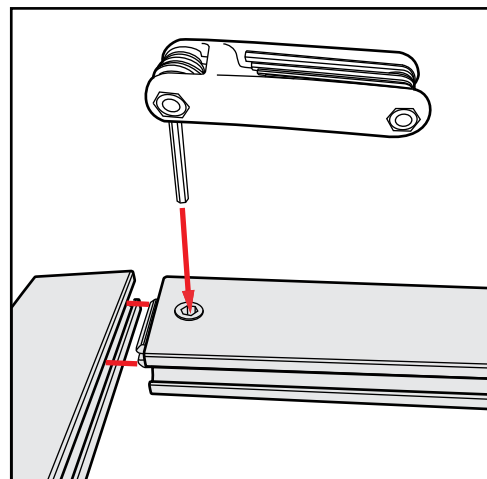

Extrusion & Lock Connection

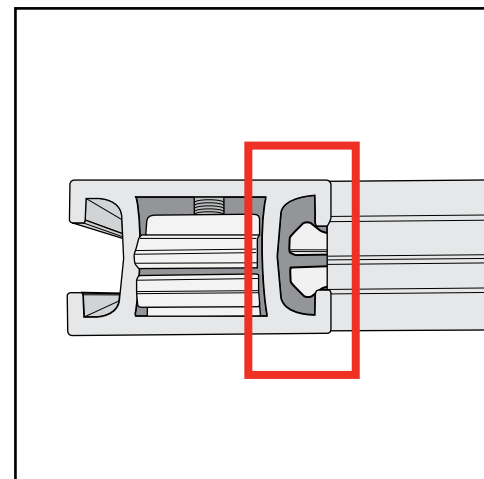

Engaged Lock



WARNING



DO NOT USE POWER TOOLS



LADDERS OR LIFTS
MAY BE REQUIRED



ALL CONNECTIONS MUST
BE TIGHTLY SECURED

Top View of Each Level

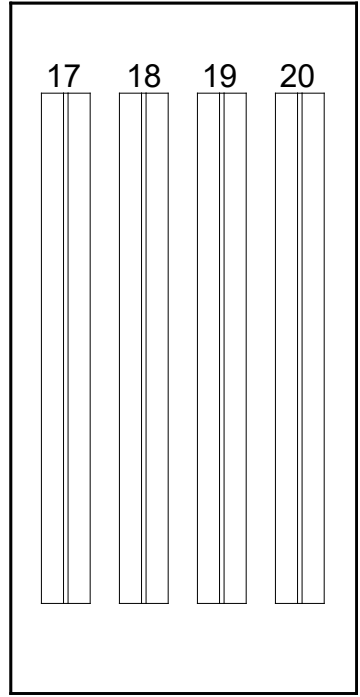

Level 1
(Bottom level)

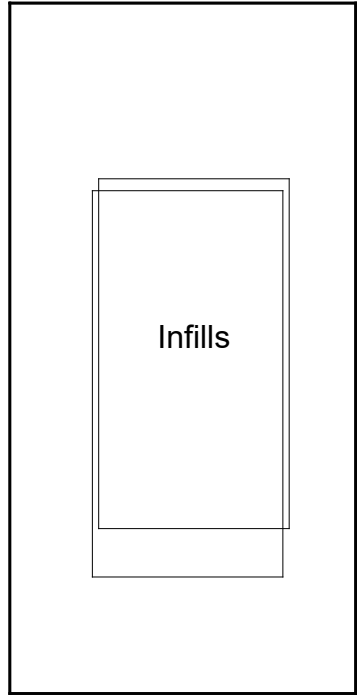

Level 2

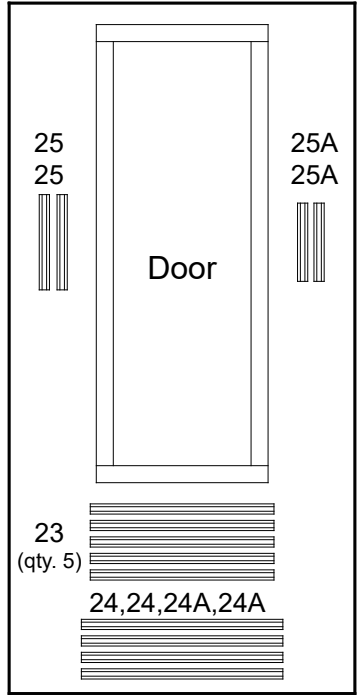

Level 3

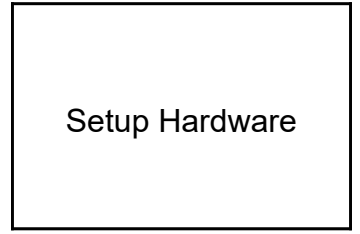

Top View of Each Level

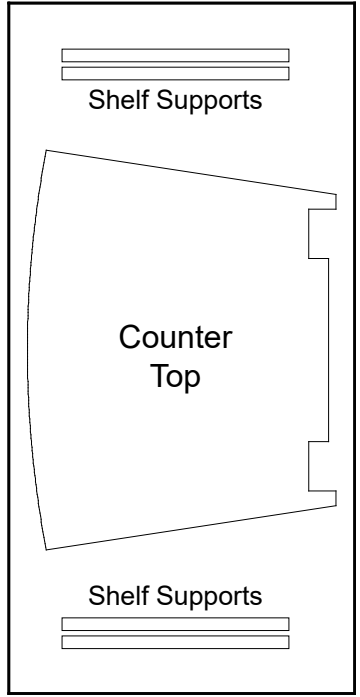

Level 1
(Bottom level)

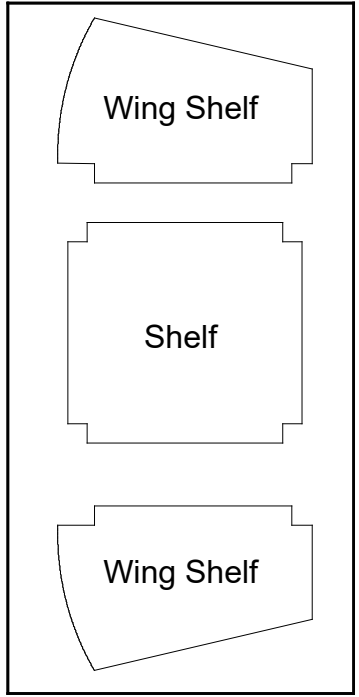

Level 2

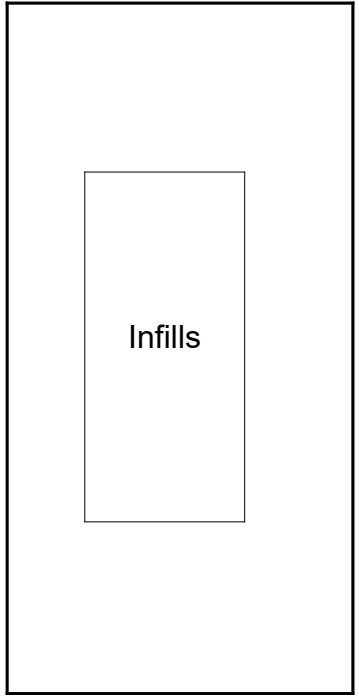

Level 3

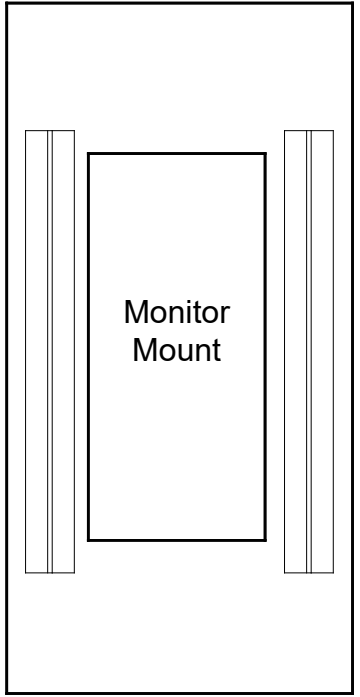

Level 4